

Fig. 1 - metering device EVD-FL-L

4405a02

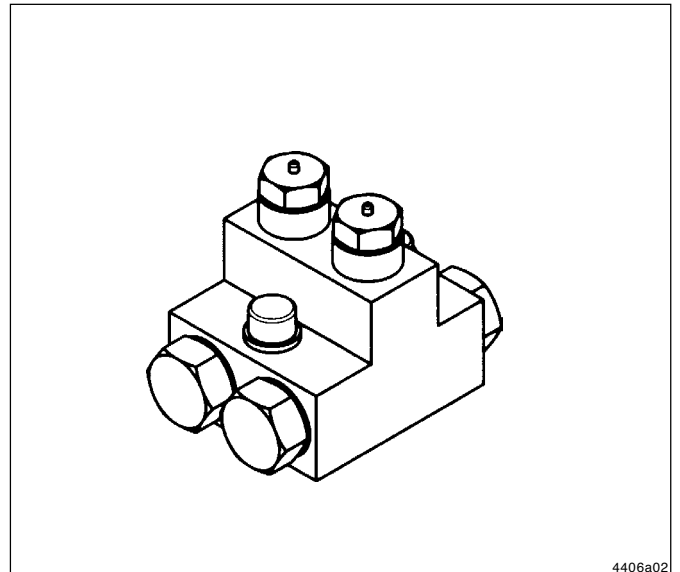

Fig. 2 - metering device EVD-FL-S

4406a02

## General Information

### Appropriate Use

Use the single-line flange metering devices of the EVD-FL series only for the supply of lubricant in centralized lubrication systems.

### General Safety Instructions



**Do not install or remove the metering devices when the system is under pressure or the pump in operation.**

- Always protect the centralized lubrication system connected to the pump with a pressure reducing valve.
- Incorrect operation may lead to damage resulting from insufficient or excessive lubrication of bearings or lubrication points.
- Your own alterations or modifications of an installed system should only be carried out if approved by the manufacturer or his appointed dealer.
- Use only original LINCOLN spare parts or parts authorized by LINCOLN.

### Regulations for Prevention of Accidents

- Adhere to the rules valid in the country where the unit will be in operation.

### Operation, Maintenance and Repair

Repairs must be carried out only by qualified persons who have been charged with the repair work and are familiar with centralized lubrication systems.

Since the pistons in the metering devices are fit with the smallest tolerances, the metering device must be replaced completely when the pistons are worn.

When synthetic lubricants are used, bear in mind that they must be compatible with the sealing material of the metering devices (polyurethane or Viton).

Use only lubricants which are appropriate for centralized lubrication systems. In case of doubt, ask the supplier.

### Installation

CAUTION

**For all works at the metering device, observe extreme cleanliness**

- Attach the metering devices to even surfaces without tension.
- Protect the metering devices from dust and influences of heat (observe the maximum admissible operating temperatures).
- The metering devices must be easily accessible for check and installation work.
- € Before connecting the feed lines to the metering devices, fill them with lubricant.

Technical Data

EVD-FL-L2

EVD-FL-S2

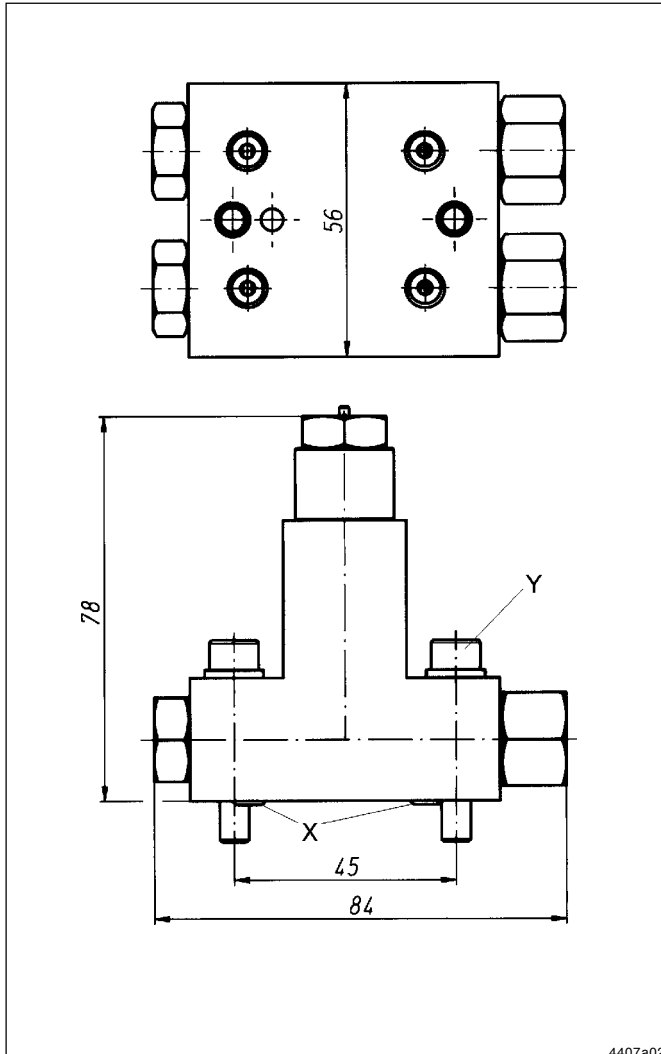

4407a02

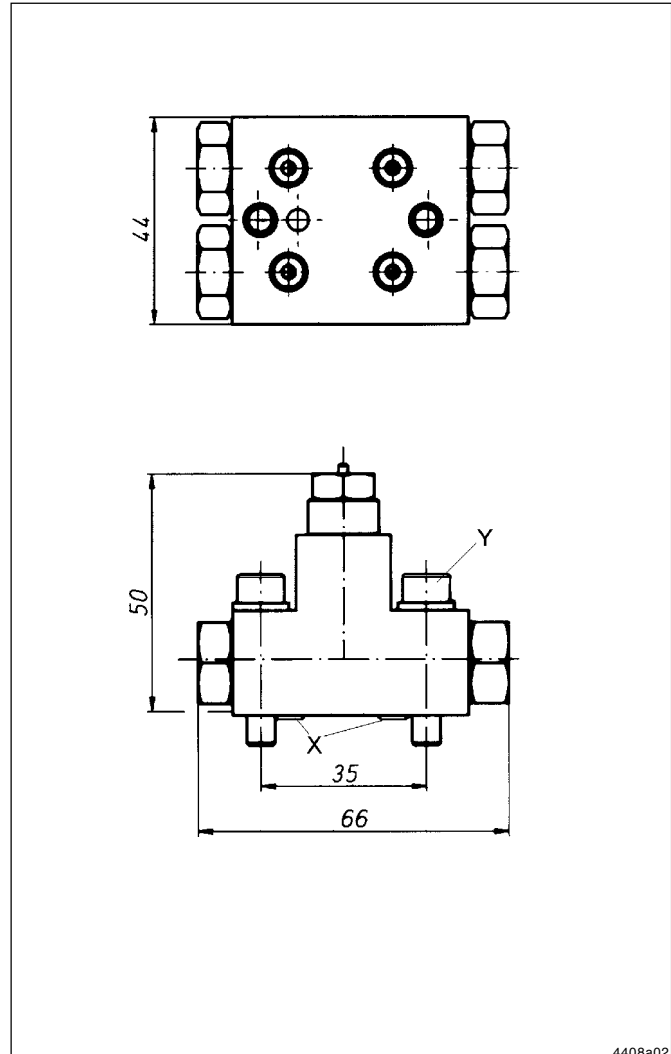

4408a02

Fig. 3 - dimensions EVD-FL-L2

Fig. 4 - dimensions EVD-FL-S2

Technical Data:

Output volume:	EVD-FL-S: 0.05 cm <sup>3</sup> / stroke EVD-FL-L: 0.65 cm <sup>3</sup> / stroke
Operating pressure:	max.: 80 bar
Relief pressure:	max: 3-5 bar
Operating temperature:	-26° C to +93°C
Connections:	via flange plates and O-rings X: O-ring 6x1.5 part n°. 219-12222-3 Y: Hexagon socket head screw M6x35 (part n°. 201-12819-1) for EVD-FL-L M6x30 (part n°. 201-12476-9) for EVD-FL-S
Tightening torque:	8 Nm + 10 %

Subject to change without notice

Function Description

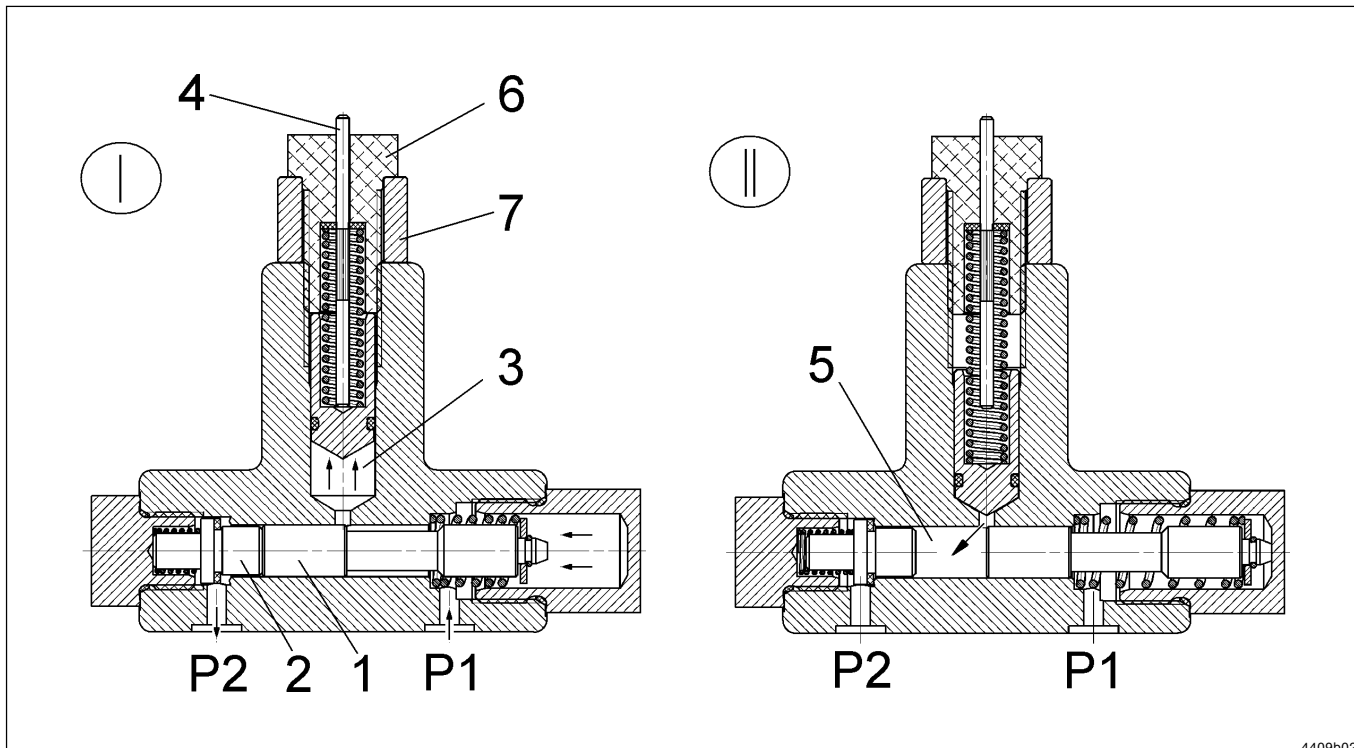

Fig. 5 - function EVD-FL

4409b02

- I Metering device pressurized
- II Metering device on pressure relief
- P1 Inlet (oil supply line from pump)
- P2 Outlet (oil feed line to lubrication point)
- 1 Discharge piston
- 2 Check valve
- 3 Measuring chamber

- 4 Indicator pin
- 5 Discharge chamber
- 6 Adjusting cap (tightening torque: 17 Nm + 10%)
- 7 Metering ring:
  - 0.65 cm<sup>3</sup>: p.no. 439-24879-1
  - 0.05 cm<sup>3</sup>: p.no. 439-24881-1

**Fig. I Stage of build-up of pressure and lubrication**

(State: Discharge chamber (5) filled with oil from previous lubricating cycle).

The central lubrication pump builds up pressure in the oil supply line. The discharge piston (1) is forced to move under the pressure of the incoming lubricant when the oil pressure is exceeding 51 bar at the inlet (P1) of the metering device.

The discharge piston (1) pushes the oil in the measuring chamber under pressure to the outlet (P2) in the feed line to the lube point whereby the check valve opens the outlet passage.

When the discharge piston (1) has passed the bore to the measuring chamber (3), the latter is charged with oil under pressure.

The adjusting cap limits the travel of the measuring chamber piston. During the travel, the indicator pin moves to extended position thus enabling a visual control of the function.

After the discharge piston has completed its travel, the metered amount of oil is pushed out of the discharge chamber (5) to the outlet (P2) through the check valve (2); thereafter the pressure relief of the lubricant supply line to follow.

**Fig. II Stage of pressure relief**

After completion of each lubricating phase, the supply line (oil line between pump and metering device) must be relieved from pressure to admit the metering device to change-over.

The pressure at the metering device inlet (P1) must drop below 3-5 bar.

The compression spring retracts the discharge piston to normal position.

The check valve (29) prevents the oil from flowing from the feed line back to the discharge chamber (5).

When the fitted-type discharge piston has passed again the bore to the measuring chamber (5), the metered amount of oil is automatically shifted from the measuring chamber to the discharge chamber (5) by the spring-loaded piston of the measuring chamber.

After this, the metering device is ready for the next lubrication cycle.

The indicator pin remains in its extended position and has to be pushed back by hand, if a control is desired for the next lubrication cycle. By doing so, faults on the metering devices remain visible also during the lubrication pauses.

Subject to change without notice

**Identification Chart EVD-FL**

Examples for model designations:

EVD - FL - L 2 KD0,65 P-No. 639-40840-4

EVD - FL - S 2 KD0,05 P-No. 639-40841-4

Single-line metering device,  
 directly actuated

Flanged version

S: Small  
 L: Large

Number of outlets

KD: Indicator pin, firmly adjusted measuring

Output volume...cm<sup>3</sup> per stroke

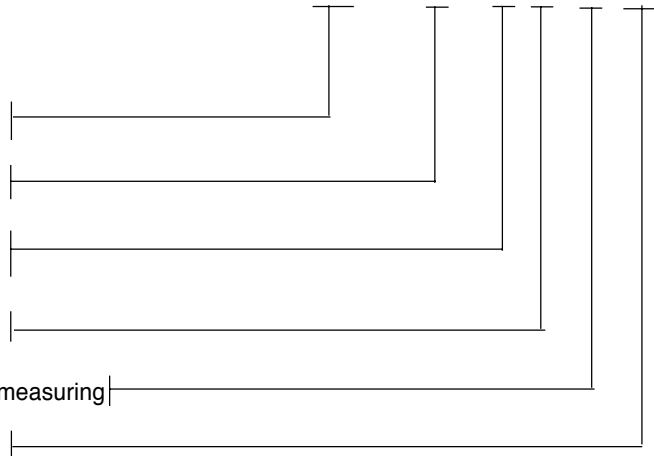

**Venting of the metering device plates**

When mounting the metering device plate or removing a metering device and then mounting a new one onto the flange plate, vent the main line bores on the flange plate before the start-up.

The following drawing shows the metering device plate AIS with adapter plate. The same principle is valid also for the other flange plates.

Venting:

- Loosen closure screws position A
- Let system run until oil comes out free of bubbles
- Retighten closure screws, tightening torque: 10 Nm ± 10 %
- Check whether all metering devices are operating. (Control pin must be pressed in evenly; if the control pin comes out again, this means the metering devices are operating.)

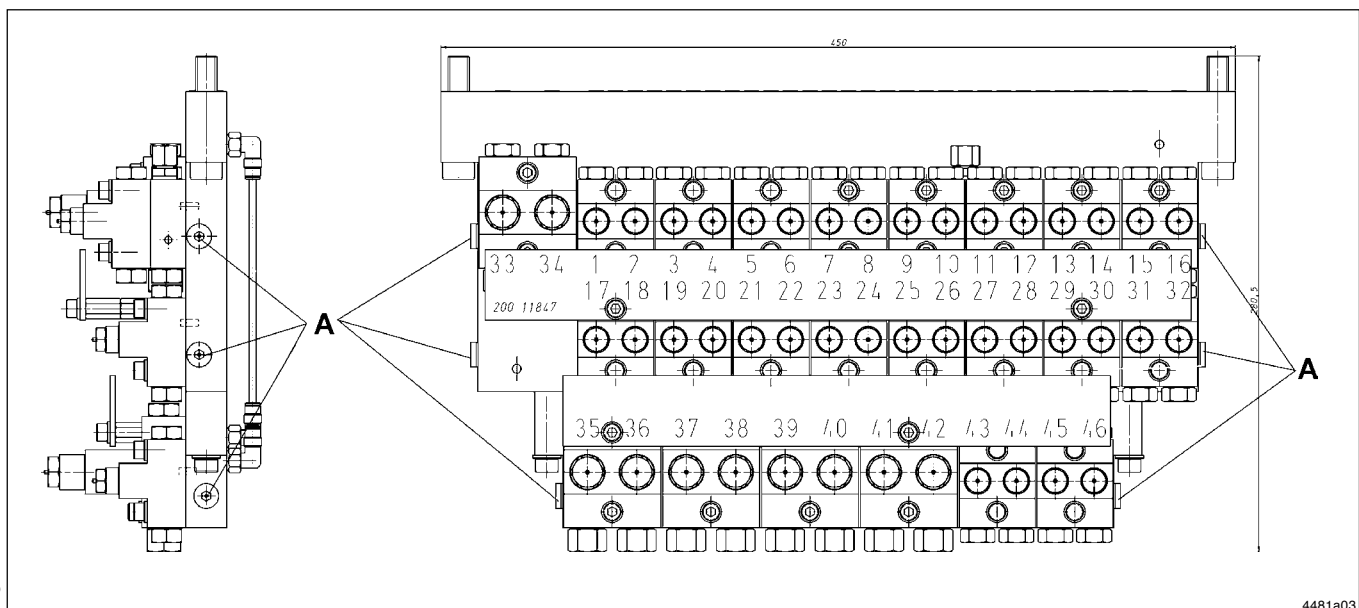

Fig. 6 - metering device plate

Subject to change without notice